

# LUMUX

Date :

Project :

Type:

Agency :

Distributor :



Low profile LED Stainless Steel Step light. The grade of stainless steel cover is 316 which is fastened with stainless steel vandal resistance to its low copper aluminum die cast body. Unit is provided with polymer rough in housing for concrete pour applications. The Concrete pour box (CPX) could be shipped in advance for any prior concrete job. The protruded crystal top of this unit is illuminated with a 1 watt CREE LED. Unit is provided with its integral driver for 120 input voltage. No need to any extra driver or transformer for the project. Unit is silicon gasketed for weather tight operation. ETL listed for wet locations.

**SPECIFICATION:**

**Housing :** Low copper aluminum die cast.  
Vandal resistance stainless steel screws.  
Silicon gasketed for weather tight operation.

**Diffuser :** Clear polycarbonate

**Electrical :** Voltage : 120 .  
Lamp: LED.

**Installation:**  
Unit is provided with polymers rough-in box. Opening size 3 15/16" diameter x 4 1/4" in length.

**DIMENSIONS:**

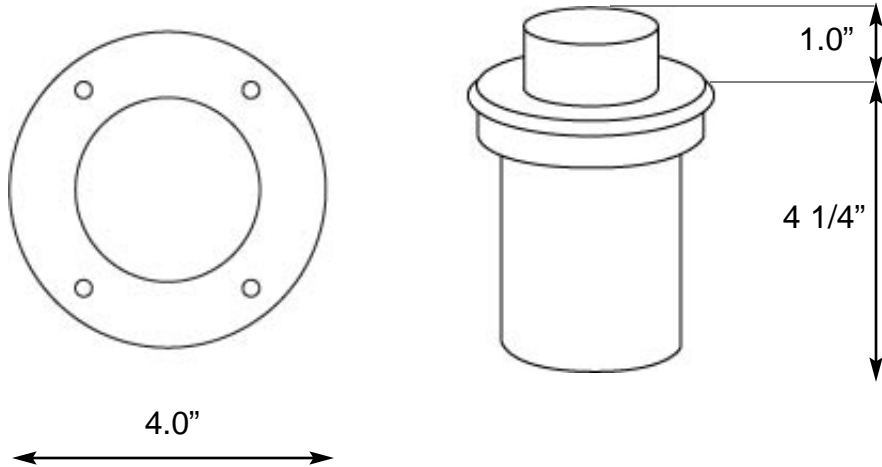

Lumux - SLC100

Lumux reserves the right to modify the above details to reflect changes in the cost of materials and/or design without prior notice.

Lumux Lighting Inc	877-895-5552	Rev : A	Drawing Number SLC100
--------------------	--------------	---------	--------------------------

# LUMUX

Date :

Project :

Type:

Agency :

Distributor :

## ORDERING GUIDE:

---

SLC100 / XXX / XXX / xxx

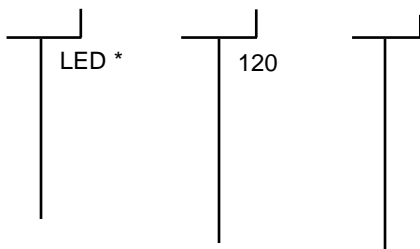

\* LED has integral driver @ 120 volt

Lumux - SLC100

## PROJECT NOTES:

---

### Comments

### Approval

Lumux reserves the right to modify the above details to reflect changes in the cost of materials and/or design without prior notice.

Lumux Lighting Inc

877-895-5552

Rev :A

Drawing Number  
SLC100